

HARMONY

Fiberdeck[®]

Never stop innovating



20
YEARS
WARRANTY
LIMITED RESIDENTIAL

UV RESIST



R12

INDIAN SUMMER

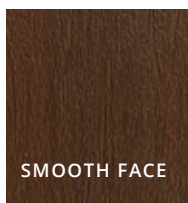

SMOOTH FACE

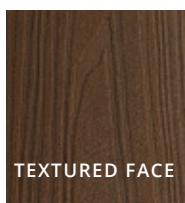

TEXTURED FACE

OCEAN GREY



SMOOTH FACE

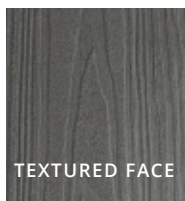

TEXTURED FACE

CEDAR

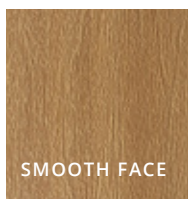

SMOOTH FACE

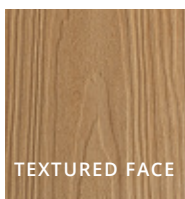

TEXTURED FACE



22.5 x 138 x 4000 mm



22.5 x 138 x 3000 mm



Cobra Start/End
(30 clips + 30 screws)



Cobra Hybrid 8-18
(90 clips + screws)
1 bag for 4.5 m² (138mm)

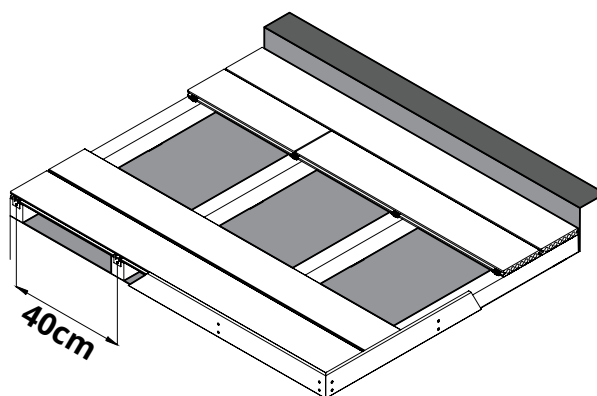

HARMONY

PROPERTY	TEST METHOD	TEST RESULTS	NOTES / REQUIREMENTS
Composition	-	HDPE = 35% Wood powder = 55% Additives = 10%	-
Density	EN 15534-1	1.240 g/cm ³	-
Linear mass	EN 15534-1	3.70 Kg/m	-
Deviation from Straightness	EN 15534-1	≤ 1 mm / metre	-
Cupping	EN 15534-1	≤ 0.5 mm	-
Maximum load	EN 15534-1	4048.28 N	Span : 400 mm F _{max} ≥ 3 300 N (EN 15534-4)
Deflection at 500 N	EN 15534-1	1.02 mm	Span : 400 mm ≤ 2.5 mm (EN 15534-4)
Modulus of elasticity	EN 15534-1. Annex A	4374.1 MPa	Span : 400 mm Bending test on finished product at normal condition 20°C and 65% RH
Bending strength	EN 15534-1. Annex A	32.56 MPa	
Creep behaviour	EN 15534-1	Max ΔS = 1.64 mm Mean ΔSr = 1.15 mm Creep factor = 1.14 Creep recovery = 41.5 %	ΔS ≤ 13 mm for individual values ΔSr ≤ 5 mm for arithmetic mean value (EN 15534-4)
Resistance to indentation (Brinell Hardness)	EN 15534-1	Brinell hardness : 66.5 MPa Rate of elastic recovery : 65.9 %	Applied load : 2000 N
Resistance to artificial weathering	EN 15534-1	ΔE = 1.14	2000 hours. ISO 4892-2 cycle 1
Swelling and water absorption (28 days)	EN 15534-1 EN 317	Swelling: 0.13 % in thickness 0.05 % in width 0.14 % in length Water absorption in weight : 2.51 %	Swelling: ≤ 4 % in thickness ≤ 0.8 % in width ≤ 0.4 % in length (EN 15534-4) Water absorption in weight ≤ 7 % (EN 15534-4)
Boiling test	EN 15534-1 EN 1087-1	Water absorption in weight = 0.79 %	Water absorption in weight ≤ 7 % (EN 15534-4)
Falling mass impact resistance	EN 15534-1	No crack	Striker weight : 1000 ± 5 g Falling distance : 700 ± 5 mm No cracks on 10 test specimens. (EN 15534-4)
Surface bond strength	EN 319	6.45 N/mm ²	-
Abrasion	ASTM D4060-19	50.7 mg	-
Slipperiness	DIN51130 (R classification)	Test direction width : R12 Test direction length : R11	Textured face
Heat reversion	EN 15534-1 EN 479	0.12%	100°C - 1 hour
Linear thermal expansion coefficient	EN 15534-1	34.8 10 ⁻⁶ K ⁻¹	≤ 50.0 10 ⁻⁶ K ⁻¹ (EN 15534-4)
Reaction to fire - Single flame source test	EN 15534-1	Class _{EN}	FS ≤ 150 mm within 20 s. (EN13501-1)